

SAFE KITCHEN

INTRODUCTION

Now a days automation plays a vital role in daily human life. Different processes in human life are automated by different electronic appliances e.g. washing of cloth (washing machine), controlling of room temperature (A.C.), etc. Actually man is surrounded by machine.

Here a project is develops which is beneficial for human in terms of safety of HOME is concerned. In this project we are considering the parameters like Temperature, LPG, Smoke and Water. After considering all these factors our project will take preventive action i.e. by warning and taking some action according to problem.

The main controlling unit for this project is the microcontroller 89c55 which consists of 20 bytes of In-system Reprogrammable Flash Memory ,256*8 bit Internal RAM, 32 Programmable i/o lines, Three 16-bit Timer/Counters.

Other units in project are 16*2 LCD Display , Smoke sensor, Temperature Sensor, LPG sensor, Smoke sensor, ADC 0808, Buzzer, Sprinkler, Solenoid valve.

BLOCK DIAGRAM

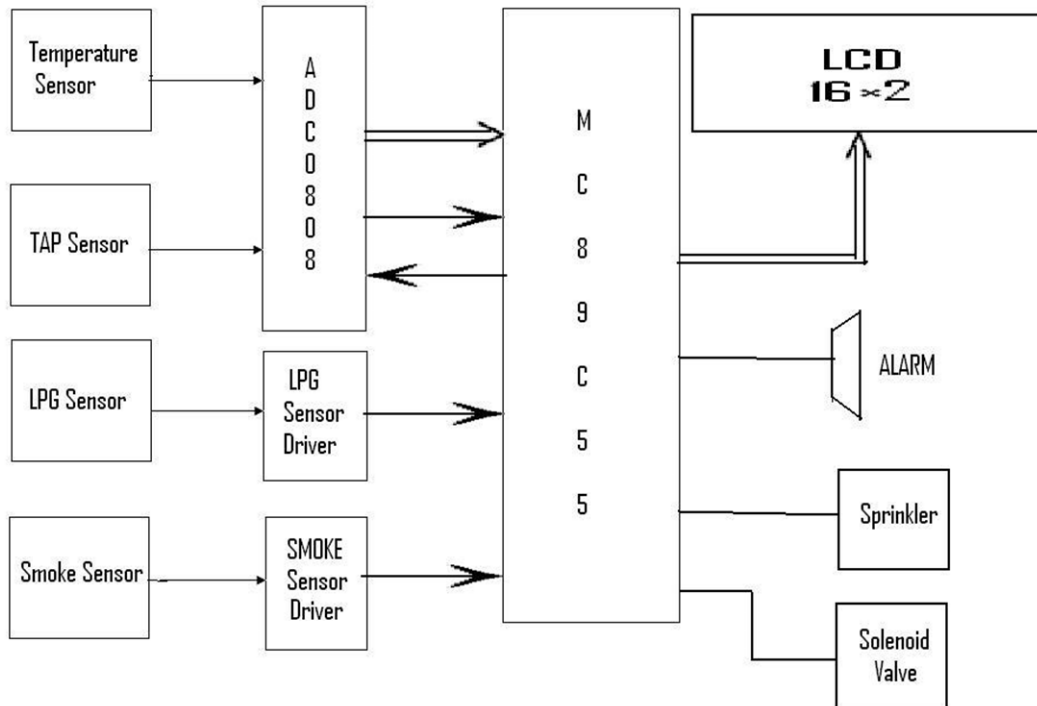

Above figure shows the block diagram for the 'E-HOME' which includes:-

1. Micro-controller 89c55:-

This is the main controlling unit for the system. This unit receives the data from sensors and take corresponding action according to data received.

2. ADC 0808:-

The ADC 0808 is used to convert analog data into digital one which is received by it from Temperature sensor and Tap sensor.

3. LCD(Liquid Crystal Display):-

16*2 LCD is used to display the condition of different sensors i.e. status of E-HOME.

4. Smoke Sensor:-

This sensor is used to detect smoke inside the room.

5. LPG Sensor:-

This sensor is used to detect LPG inside the room.

6. Temperature Sensor:

This sensor is used to detect the temperature of room.

7. ALARM , SPINKLER AND SOLENOID:-

These are used to take control action according to remedies that was observed from the data from the sensor.

