

ENERGY EFFICIENT HOME AUTOMATION SYSTEM

INTRODUCTION:

Energy saving is the major issue in the world. This project is developed to save the energy in terms of electricity. The microcontroller based circuit is developed. This circuit checks the availability of human being in the room. If nobody is available in the room all appliances will be automatically switched off. If anyone enters in the room, the light condition and temperature of the room will check by the ckt. If temperature is above threshold cooling appliance will be switched on. Temperature threshold can be set by switches. Second, light condition will be checked and if enough light is not available, light will switch on. If person goes out from the room and if nobody available in the room all appliances will switched off. The block diagram gives the complete idea of the system.

Block diagram

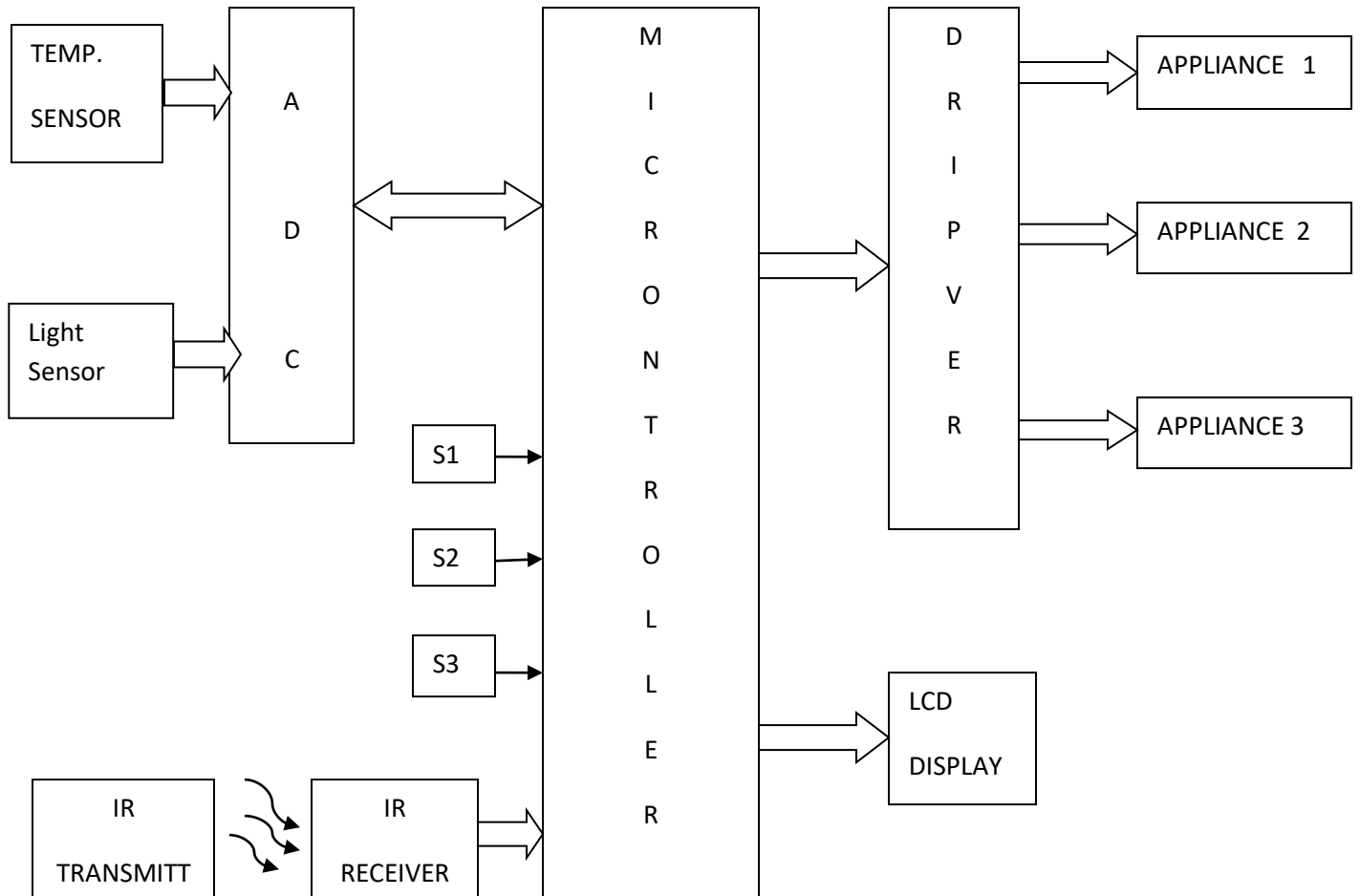

The system consists of following block

Micro switch is used to set the threshold for temp

Driver: it is combination of relays and driver ckt. Required to drive the relay e.g transistor