

AUTOMATIC POWER SAVING MICROCONTROLLER TEMPREATURE CONTROLLER AND LIGHT CONTROLLER

This is hardware base project in these project electric power is saving through the micro controller and also time saving.

This circuit contains two IR trans receivers, micro controller, Relay driver circuit, Relay, 16 * 2 module LCD screen, 0808 ADC and LDR and temperature sensor.

In this type of circuit two IR sensors is connected to micro controller which is placed near the Gate, between these two IR sensor length is absolute 20-25cm. When the person is entering then IR sensor get affected and IR2 sensor is getting affected when any person is exit. There is three Relay is connected to micro controller throughout Relay driver which is capable drive the current of Relay. In these CKT Relay one is get connected to the main line of power supply. Relay two is connected to heater or AC, Relay there is connected to micro controller which is given the Analog value of temperature sensor and LDR sensor into digitally form. 16 * 2 Module LCD display is connected to micro controller of port 3 which is displayed temperature and counter of entering persons.

When any person is enter then some binary acknowledge is given to micro controller. Then suddenly it drivers the main phase relay. Power takes ON, then the temperature LM35 and light sensor LDR is gives the Analog values to ADC 0808 it converts into digitally form. Calculation is takes placed weather the temperature is low the heater is ON state through Relay. On the other hand temperature is high heater is OFF state.

The porch / pole lamp is driver to directly proportional to values to light intensity when the light intensity is high the micro controller driver the pole relay is OFF state and intensity is low (or night) then the lamp is ON state.

When all the persons get exit then micro controller drive main phase power supply Relay to OFF all power supply.

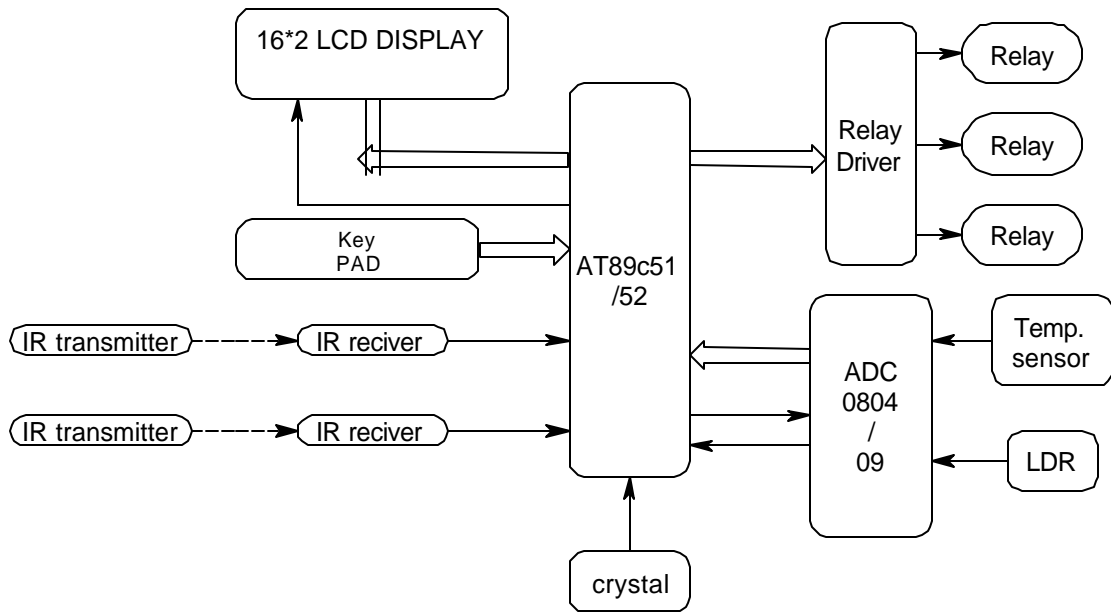

“AUTOMATIC POWER SAVING” USING MICROCONTROLLER

This project is hardware based project. In this project, electric power is saving through the MICROCONTROLLER and also time saving.

This circuit contains 2 IR Tran receivers, Microcontroller, Relay driver circuit, Relay, 16*2 Model LCD screen, 0808 ADC, LDR and temperature sensor.

In this type of circuit, 2 IR sensors are connected to microcontroller which is placed near the Gate, between these two IR sensor, length us about 20-25 cm. When the person is enter then IR sensor get effected and IR sensor is get effected when any person get exit. There are three Relays which they are connected to Microcontroller, throughout Relay driver which is capable to drive the current of relay. In this circuit Relay 1 is get connected to the main line of power supply. Relay 2 is connected to the Heater of AC. Relay 3 is connected to the porch/pole lamp. 1 ADC is connected to the Microcontroller which is given the Analog value of temperature.

We can quickly make the relay on/off using keypad for local operation

To indicate the status of relay, there is a LED indicator.

Additional Function :

A specific key is allocated for all Relay's ON,
Second specific key is allocated for all Relay's OFF.